

OPERATING MANUAL

MAXI SKY 1000®

CEILING LIFT SYSTEM

MAXI SKY 1000

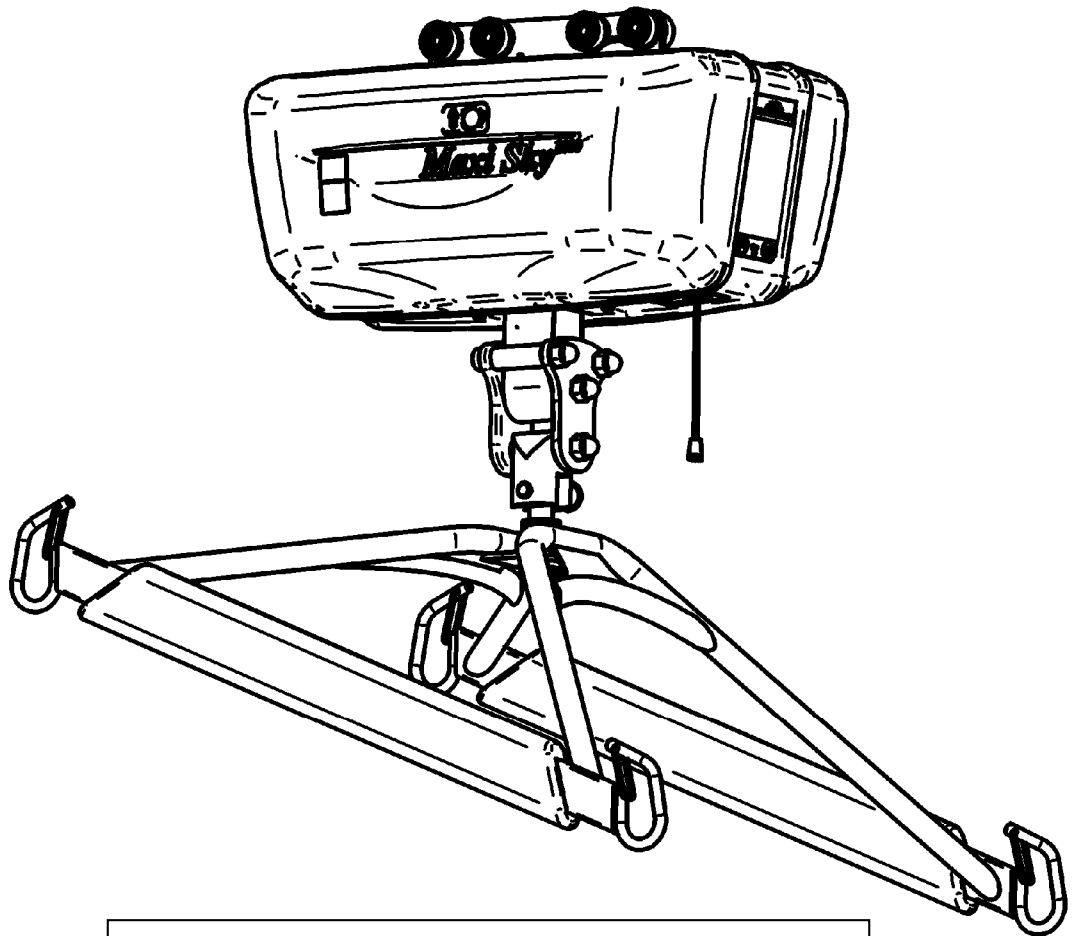

**DO NOT DESTROY
KEEP THIS MANUAL WITH THE LIFT AT ALL
TIMES.**

Arjo designs and manufactures quality engineered patient lifting equipment for the care of the disabled in hospitals, nursing homes and home care.

Please take the time to read the entire manual, including the section on Safety Instructions and Warnings. It contains important information that will allow you to take advantage of all the characteristics of your ARJO patient lift.

Arjo Credentials

- FDA Registration # 9681684
- CE mark (European Union Listing)
- Global operations for in-warranty and out-of-warranty service support for MAXI SKY 1000 lift.
- Each finished MAXI SKY 1000 is individually tested in our laboratory.
- Lifting capacity is 455 kg (1000 lbs). Engineering safety factor exceeds European Standards.
- Complete range of patient lift slings and supports designed and manufactured by Arjo Inc. using medical quality materials and fabrics.
- ISO 9001

APPROVALS:

CSA 601.1
UL 2601.1
EN 60601.1
EN ISO 10535 (Lifting device) SGS
UK Test Report: DUR22107/AC/OO

Note: Arjo is constantly improving its products. For this reason, it may be possible to encounter a modification of product without revision of this manual.

Thank you for trusting your Arjo Partners.

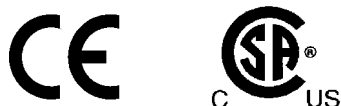

TABLE DES MATIÈRES

INTRODUCTION	5
How to use this Manual	5
Equipment Identification	5
Verifying the Package Contents	5
Key to Symbols	5
SAFETY INSTRUCTIONS AND WARNINGS	6
DESCRIPTION OF EQUIPMENT – MAXI SKY 1000	8
Lift Unit	8
What’s included	8
Dimensions	8
Parts description	9
OPERATION	10
How to use the MAXI SKY 1000	10
Emergency Stop (Red Cord)	11
Emergency Lowering Feature	11
Emergency Brake	11
Battery Information	12
Indicator Lights	12
Charger Specifications:	13
Using the FIDO function (Pre-programmed positions)	13
Programming the Lift	14
MAINTENANCE	15
Daily Check List	15
Inspection and Cleaning	15
Strap Inspection	15
Handling and Storage	16
Battery Replacement	16
Sling Inspection and Care	16
Annual Inspection	17
Maintenance Requirements	17
ERGOFIT SLINGS	18
Bariatric Sling (TOB)	19
MAINTENANCE INSPECTION CHECKLIST	20
TROUBLESHOOTING	21
ACCESSORIES	23
LOGBOOK	24
WARRANTY	26

© 2004 **WARNING!**

All rights reserved. CONFIDENTIAL. The reproduction of this document or the transmittal in any form of any information, contained herein, without the authority in writing of an officer of the manufacturer is prohibited.

TECHNICAL SPECIFICATIONS AND DESIGN SUBJECT TO CHANGE WITHOUT NOTICE.

INTRODUCTION

How to use this Manual



DO NOT ATTEMPT TO USE THIS EQUIPMENT WITHOUT UNDERSTANDING THIS MANUAL.

To ensure safe operation, read the entire manual carefully, especially the section on "Safety Instructions and Warnings", before installing, operating, or servicing this equipment.

If anything is not completely understood, please contact your supplier for more details. Failure to comply with warnings in this manual may result in injuries.

Keep this manual with the lift and refer to it as required. Contents of this manual are subject to change without prior notice to users.

Throughout this manual, the following symbols may appear. Pay particular attention to the information provided under these headings. These special annotations are easily recognized as follows:



WARNING: this symbol is intended to alert the user to hazards or unsafe practices, which could result in serious bodily harm.



CAUTION: this symbol is intended to alert the user of the presence of important operating and maintenance instructions, which could prevent product damage or possible personal injury.



NOTE: this symbol offers helpful information concerning certain operating procedures.

You can purchase additional copies of this manual by contacting your supplier. Include the User Manual product number and equipment identification number.

Equipment Identification

The unit's identification number (specification, model, serial number) appears on a silver nameplate attached to the end of the lift.

Verifying the Package Contents

Upon receipt of the equipment, verify it against the packing list to ensure it is complete and inspect the equipment for possible damage due to shipping. If there is any damage, DO NOT USE the equipment and notify the carrier immediately to file a claim. Provide complete information concerning damage claims or shipping errors to your supplier. Include all equipment identification numbers and group part numbers (if any), as described above along with a full description of the damaged parts.

Key to Symbols

The following symbols are used on the MAXI SKY 1000 lift:



This symbol indicates the power-on indicator.



This symbol indicates the charging indicator light.



The symbol indicates the light "Service".



This symbol represents the emergency stop.

The following symbols are used on lifter's attachment labels:



This symbol is required to be displayed on regulated products for sale in the European Market. It indicates that the product complies with applicable European Directives related to health, safety and environment, and consumer protection.



Safe Working Load represents the maximum load the lifter is rated for safe operation.

The following symbols are used on sling labels and related to washing instructions:



Maximum washing temperature is 60°C (140°F) in permanent cycle.



Do not use bleach.



Do not dry clean.



Tumble dry low temperature.



Do not iron.

Please refer to individual sling labels for complete instructions regarding washing and drying.

SAFETY INSTRUCTIONS AND WARNINGS**A. GENERAL**

- **IMPORTANT – READ THESE INSTRUCTIONS CAREFULLY OR SERIOUS INJURY MAY RESULT.**
- **KEEP THESE INSTRUCTIONS AND THE KEY PROVIDED WITH THE LIFT AT ALL TIMES.**
- **READ OPERATION AND MAINTENANCE INSTRUCTIONS IN THIS MANUAL BEFORE INSTALLING, OPERATING, OR SERVICING THIS EQUIPMENT.**
- **Arjo ceiling lifts must be installed by an authorized contractor or installer.**
- **Installation must be conformed to accept a 1000 lbs (455 kg) load. (For more information, consult the Installation guide)**
- **Only certified technician or installer can remove and reinstall the lift into track.**
- **The MAXI SKY 1000 unit is used only on a straight track. The use of curved rails is prohibited.**
- **YOUR LIFT is for transferring patients only. Do not use the lift for any other purpose.**
- **ALWAYS carry out the daily checklist before using the lift.**
- **Arjo ceiling lifts are specifically designed for Arjo ceiling rail systems, slings and accessories. Slings and accessories designed by any other manufacturer are prohibited and will void Arjo warranty. Use only Ergofit slings and accessories to maintain patient safety and product utility.**
- **Arjo ceiling lifts are intended to be used for patients within the specified weight limit indicated for the lift. Do not attempt to lift more than the weight limit indicated.**
- **Before attempting to transfer, the patient must be assessed by a qualified professional.**
- **Arjo ceiling lifts must be used by a caregiver with proper training to work with the patient to be transferred.**
- **ONLY trained and qualified caregivers should transfer a patient. DO NOT attempt to use the lift if you have not been properly trained to do so.**
- **ALWAYS be prepared before attempting to transfer a patient.**
- **DO NOT use a sling that is not recommended for the lift.**
- **NEVER use a damaged, torn or frayed sling.**
- **ALWAYS place the sling around the patient according to the instructions enclosed.**
- **FOLLOW lifting procedures outlined in this manual.**
- **USE all controls and safety features only according to the rules specified in this manual. Never attempt to force a control or button on the lift.**
- **DO NOT store the charger in a shower, bath or other areas with high humidity.**
- **DO NOT drop the patient lift or batteries. Dropping the lift or batteries may cause internal damage that is not easily seen. If the lift is suspected to be damaged, take to an authorized technician for servicing.**
- **Do not put fingers into the strap and pulley system or it could result in injuries.**
- **IMPORTANT: Keep all components of the lift clean and dry, and have electrical and mechanical safety checkpoints done as instructed in the "Maintenance" section of this manual.**
- **Replace any precautionary or instruction labels that cannot be easily read.**
- **Avoid violent shock during transportation.**

B. SHOCK PREVENTION

- **DO NOT touch or use a lift with bare conductors or a damaged power cord. Electrically live equipment can electrocute a patient. If the lift or charger has any exposed or damaged wires contact your local dealer immediately.**
- **DO NOT splash or expose electric parts of the device to water or moisture.**
- **CHECK nameplate for voltage and cycle requirements. These requirements differ by country. Do not attempt to use the lift in an area that has a different voltage and cycle requirement.**

SAFETY INSTRUCTIONS AND WARNINGS

- **DO NOT** attempt to expose, service or repair the lift, battery or charger. If any unit is malfunctioning, contact your local dealer.
- **READ** batteries and charger instructions thoroughly before using or storing them.

C. FIRE AND EXPLOSION PREVENTION

- Batteries may explode, leak and cause personal injury if not disposed of properly.
 - Do not place or store the battery under direct sunlight or near a heat source
 - Do not dispose of in fire
 - Do not short the battery terminals
 - Flush with water if electrolyte (Acid) comes in contact with skin or eyes.
- Batteries must be recycled, disposed of according to local law regulations. When returning batteries, insulate their terminals with adhesive tape, etc. otherwise, the residual electricity in used batteries may cause fire or explosion.



D. EQUIPMENT WARNING LABELS

- **INSPECT** all precautionary labels on the equipment. Order and replace all labels that cannot be easily read.



IMPORTANT :

CONNECT THE CHARGER AT LEAST 8 HOURS BEFORE THE FIRST USE OF THE LIFT IN ORDER TO COMPLETELY RELOAD THE BATTERIES.

DESCRIPTION OF EQUIPMENT – MAXI SKY 1000

Lift Unit

The lift unit is a steel frame based system driven by a gear reduced high torque motor.

OPERATING FEATURES:

- Lifting capacity: 450 kg (1000 lbs).
- Average weight: 22 kg (48 lbs) batteries included.
- Electronic soft-start and soft-stop motor control.
- Emergency lowering device.
- Emergency stop device.
- Current limiter for circuit protection in case of overload.
- Safety device that stops the motor to lift when batteries are too low.
- Safety device that stops the motor to lift when abusing use of the lift causes internal overheating.
- Lifting speed: 3 cm/s (1.2 in/s.) at 450 kg (1000 lbs), 4 cm/sec. (1.6 in/s.) at 230 kg (500 lbs) and 6 cm/s (2.3 in/s) at 0 kg (0 lb).
- Horizontal displacement speeds: 10, 14, 16 and 20 cm/s. Speed by default 16 cm/s. (6,3 in/s.).
- Horizontal axis motors: 24 VDC, 62 watts and 2 vertical axis motors: 24VDC, 110 w.
- Emergency brake (in case of mechanical failure). Operates on the same principle as a car safety belt mechanism
- Strap length up to 2.3 m (90 in.) tested for 2275 kg (5000 lbs.).
- CSA No 601.1, UL No 2601-1 and CE certifications.
- Respect EMI standards
- ISO 10535.

What's included

ITEM	QTY
MAXI SKY 1000 lift	1
Batteries (inside unit)	2
Clip on charging station	1
Hand control	1
4-hook spreader bar	1
Power cord	1
8-mm Allen key	1
User Manual	1

Dimensions

(in millimeters)

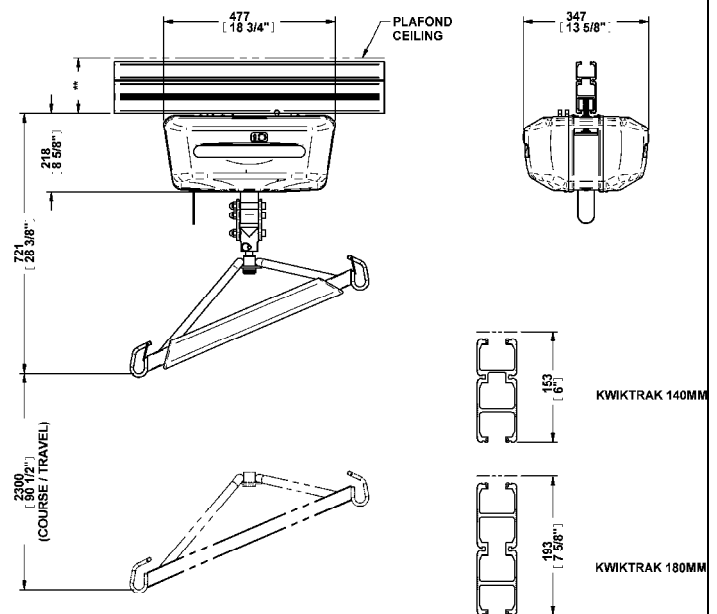

Parts description

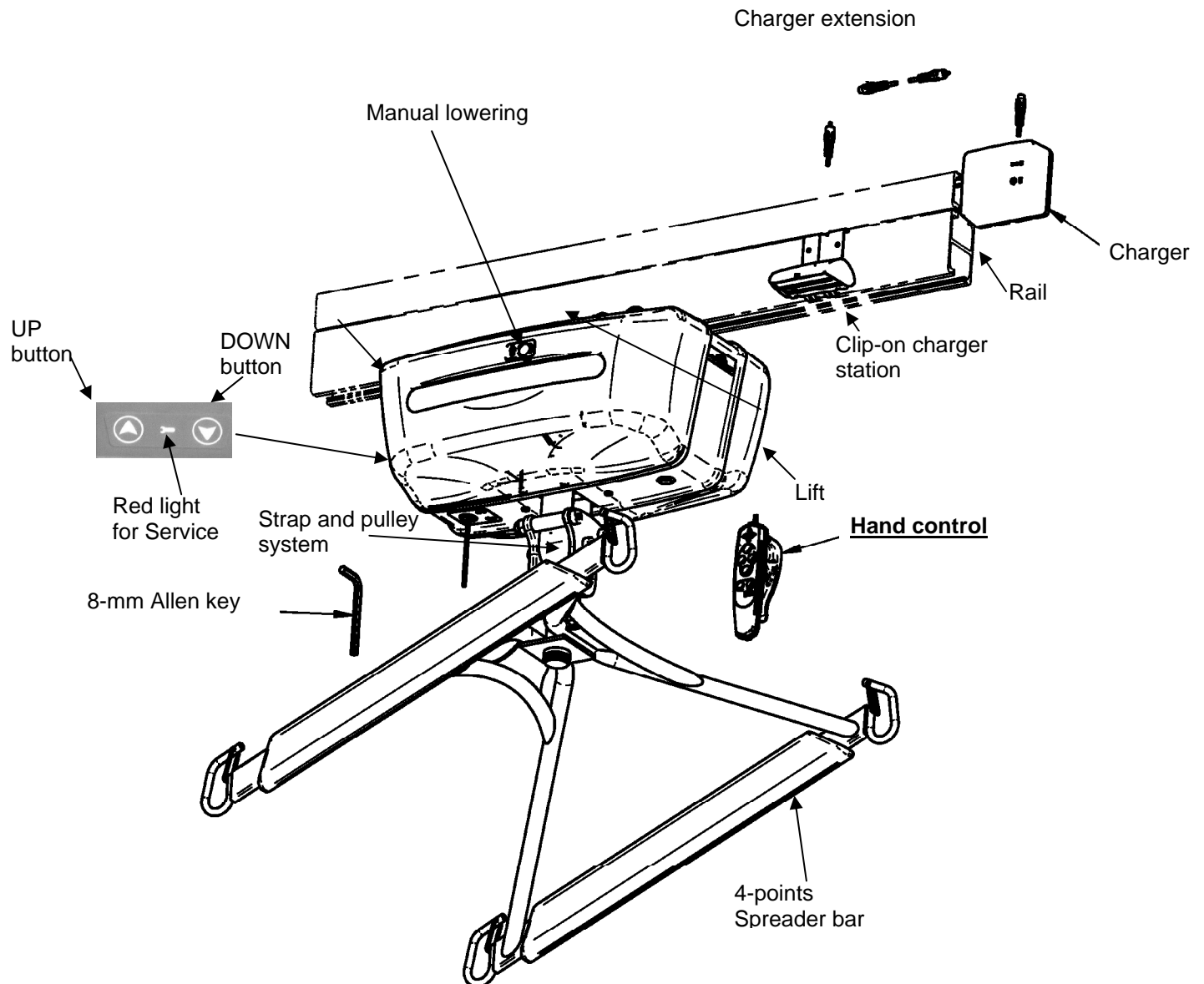
Notes:

- the yellow light "charger" flashes while charging and illuminates when charge is finished;
- the green light "on" illuminates once the lift is on and ready for use; the green light flashes when the batteries are low.
- The red light illuminates to confirm that the lift is in the programming service mode.
- The red light illuminates in the normal mode when the lift is under overheat protection causing by an overuse.
- The red light "service" flashes when servicing is required (contact customer service);
- The button "Programming mode" allows you to modify the functions of the product.

OPERATION

How to use the MAXI SKY 1000



READ « SAFETY INSTRUCTIONS AND WARNING » BEFORE ATTEMPTING TO USE THE MAXI SKY 1000.



IMPORTANT :
CONNECT THE CHARGER AT LEAST 8 HOURS BEFORE THE FIRST USE OF THE LIFT IN ORDER TO COMPLETELY RELOAD THE BATTERIES.



The unit will not lift or lower when in contact with the charger.

1. Install the patient sling (see sling instruction).
2. Move the lift directly over the patient. Use the left and right buttons the hand control.

3. Use the down button on the hand control or on the lift to lower the spreader bar under the patient's chin (to avoid the risk of facial contact caused by a sudden movement of the spreader bar) before beginning to attach the sling straps. If the lift will not operate – pull red cord once gently, until you hear a click.

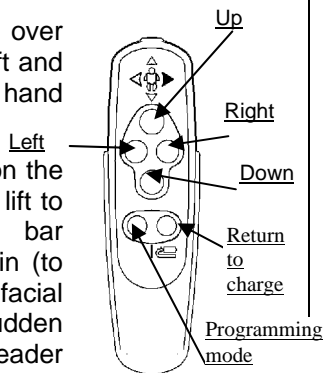

If the lift does not work, gently pull on the red cord until you hear a click. The green light should illuminate to confirm the unit is power on.

Note: In a laying down position, lower the spreader bar near the thorax, then install the straps.



Hold the lift spreader bar with one hand at all times when near a patient.

4. Attach the straps to the desired position. (See "Ergofit Slings section").
5. Carefully observe the patient to ensure his/her safety as you press the control buttons.



BEFORE LIFTING THE PATIENT:

1. Make sure that all straps are attached to the spreader bar ;
2. Make sure the patient is comfortable;
3. Make sure the sling is not caught on any obstruction (wheelchair brake or arm of the chair)

If any of the above occurs – lower the patient immediately and correct the problem.

6. To lift the patient, press on the up button,
7. Make sure the patient is clear of any obstacles before moving the patient. Guide the legs if necessary.
8. When the patient is located above the desired point of transfer, press on the down button.
9. Use the handles on the back of the sling to position the patient when transferring into a chair. Hold the hand control firmly as the sling lowers and the sling will tilt back to position the patient.
10. Once the patient is properly seated and the straps are loose, remove the sling from the lift.



Hold the lift spreader bar with one hand at all times when near a patient.

11. Slide the lift away from the patient.

12. When the lift is no longer required, return the lift to the charger station by pressing on the return button.
13. The charging indicator light must be on for the lift to detect the clip on charging station. Take note that the lift memorizes the charger station position.
14. Verify the green light at the charging station and the yellow light (flashing or light) of the lift to ensure that charge function is working properly.



The MAXI SKY 1000 is equipped with a security system to prevent a misuse of the lifting system. If the use is over the 10% of the duty cycle, the heat detection system will order to the processor to block the lifting of a load until transmission temperature cools down.

Therefore, it will always be possible to activate the horizontal displacement and the down functions.

When the overheat protection engages, the red light will illuminate during the cooling period.

Plus, a buzzer will be heard if the UP button is engaged and the motor will not lift. The cooling period is between 10 to 30 minutes.

Emergency Stop (Red Cord)

1. The emergency stop can be activated at any time to stop the functioning of the lift.
2. To stop the lift in an emergency, pull on the red cord once gently, you will hear a "click".

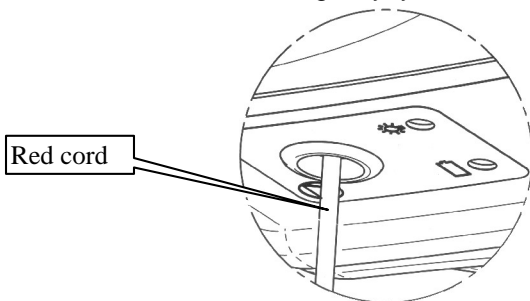



Do not pull red cord forcefully. If the cord is pulled too forcefully, the lift may become inoperable.

To activate the lift, pull the red cord once gently. The green light confirms that the lift is on.

Emergency Lowering Feature

In the event of an electrical or functional failure, the MAXI SKY 1000 has an emergency manual lowering feature.



Only to be used in case of an emergency.

If the lift malfunctions when a patient is being transferred, the emergency lower device provides a safe way of lowering the patient onto a chair or a bed.

1. Get the 8-mm Allen key provided with this manual.
2. Remove the black cap on the side of the cab.
3. Insert the Allen key deep into the gear, visible in the lateral door. Turn it counter clockwise in order to lower your patient. The key turns the main gear and each turn of the key will slowly lower your patient. Do the same with the gear on the other side of the lift.
4. To lower your patient more rapidly, use a ratchet or a drill with an 8-mm Allen key.
5. Once the patient is lowered and secure on a chair or in a bed, call a qualified technician to inspect the lift.

Emergency Brake

- The emergency brake is made of a metal bar fixed to the drum

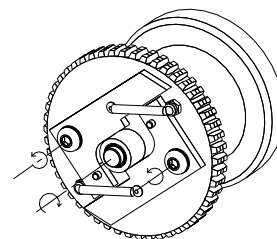

- In case of a chain, gear or motor breakage, the centrifugal force created will block the bar against the frame.

Battery Information

- 2 rechargeable batteries of 12 VDC, 7 Ah.
- Provides up to 80 transfers with a load of 230 kg (500 lbs) and up to 25 transfers with a load of 450 kg (1000 lbs).

Life cycle (number of charging cycles) of the batteries is largely dependent on the depth of discharge in each cycle. More the batteries are drained, the shorter their life span. The life of the batteries is also related to such factors as varying temperatures and rest periods between charge and discharge.

Graph 1: Number of recharges vs. Depth of discharge

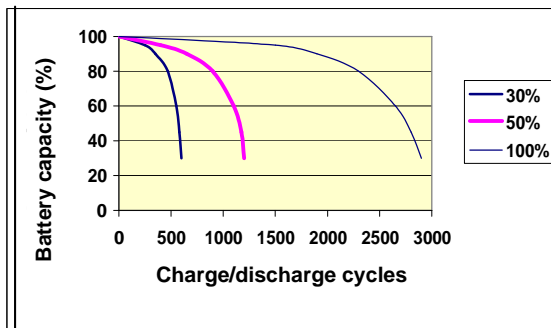

Graph 1 illustrates the relationship between the discharging depth and expected battery life. If you drain the batteries until they beep every time, you can expect the batteries to fully charge only 600 times.



To prolong battery life, return the lift to the charger WHENEVER THE LIFT IS NOT IN USE.

ARJO uses sealed lead-acid batteries. Contrary to nickel-cadmium, ARJO batteries do not have any memory effect. Therefore, batteries should not be completely drained before recharge.

Graph 2: Number of lifts vs. lift load

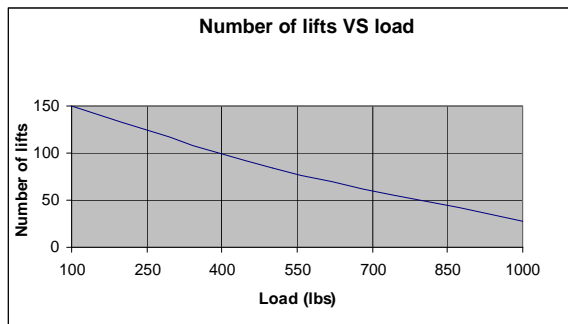



Never let a lift with the power on for a long period of time if you did not return the lift to the charger, otherwise batteries will be drained and damaged.



Do not drain the batteries excessively. This will dramatically reduce the life span of the batteries. If the low battery buzzer sounds and green light flashes, be sure to recharge the batteries as soon as possible.

Indicator Lights

The lift and the charging system have many indicator lights. It important to understand their significance for use and comprehension of the lift.

Green light	Operating the lift	
	-----	Low batteries
	—————	The lift is on and ready to use.
Yellow light	State of batteries	
	-----	In process of charging batteries
	—————	Charging done, batteries charged.
Red light	Maintenance	
	-----	Maintenance required by your local representative
	—————	Lift started by service mode or under overheat protection.

Charging indicator green light	Charger power is on
Clip on charging station indicator green light	Clip power on charging station is on
Clip on charging station red indicator	Problem with charger, do not use the charger.

Charging the batteries



DO NOT operate the charger unit with a damaged cord or if the unit has been dropped or damaged.

DO NOT forcibly bend the power cord or place a heavy object on it. This will damage the cord and may cause fire or electrical shock.

DO NOT pour liquid on or near the charger.



Do not place the unit in locations that are:

- **Extremely hot**
- **Dusty or dirty**
- **Very humid**
- **Moving or vibrating**

The recharging steps are as follow:

Press the return to charger button on the hand control. A protection device prevents the lift from returning to the charger with a load of more than 14 kg (30 lbs)

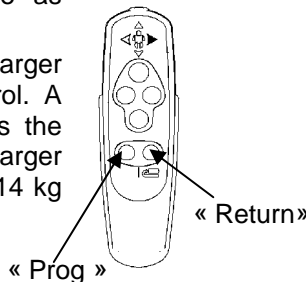

DO NOT SLIDE THE LIFT TO THE CHARGER FORCEFULLY OR QUICKLY. CHARGER MAY BECOME DAMAGED.

- The green indicator light will begin flashing if batteries are low and need to be recharged. If the light does not illuminate, verify the "Troubleshooting" section of this manual.
- The yellow indicator light will flash when the lift is returned to charger. This indicates that the batteries are being charged. Once the charge is complete the light will stop flashing and become a solid yellow light.



Whenever possible, leave the lift on the charger when the lift is not in use. At minimum, charge the batteries until the yellow light stop flashing before using it again. This will extend the life of the batteries.

If batteries have been completely drained it could take up to 6-8 hours to completely recharge them. In order to reduce charging time, refrain from completely draining the batteries and leave the lift on the charging station between uses.

Charger Specifications:

- Charger input: 100-240 Vac, 50/60 Hz.
- Charger output: 26-29 VDC, 27Va max

Using the FIDO function (Pre-programmed positions)



This function can only be activated by a certified technician.

1. Using the pre-programmed positions function allows the unit to detect stations (positions) (#700.15400.33) located along the track path. The unit will go to the indicated position by using the hand control.
2. To do so, indicate to the unit the desired position to go: **ex.: to go to the 3rd station, push three times on the PROG button followed by the direction (LEFT or RIGHT buttons).**
3. Then the unit goes by itself to the requested station and stay on hold.
4. If the position you asked for is not correct, you may stop the lift at any time by pressing any button on the hand control. From this position, re program the lift to the new desired position. Count the number of stations from where you are and indicate the direction to go.

Programming the Lift

How to program the MAXI SKY 1000?

A) Enter into the "Program" mode.

1. Turn the lift off by pulling the red cord. (The green light must be turned off)
2. Press and hold down the "PROG" button on the hand control (bottom left)
3. While holding the "PROG" button, pull on the red cord once again.
4. The green light will flash and the lift will beep three times.
5. Release the "PROG" button.
6. When the red light illuminates, this will confirm that the lift is in programming mode "Service".

The **user can easily adjust the speed and height of the lift** while in the Program "Service" Mode.

Use the "UP" button on the hand control to select the parameters desired. Each push of the button will bring you to a different selection:

- 1 beep = Speed displacement
- 2 beeps = Length of the strap
- 3 beeps = Enable/Disable return to charger

To confirm your selection, press once on the "PROG" button.

B) Speed Adjustment

1. Enter into "Service" Mode and select the first choice. (Consult section A).
2. Use the "left" button on the hand control to select the desired speed as per selection chart below. Each push of the button allows you to go from one selection to the next.

1 beep	2 beeps	3 beeps *	4 beeps
10 cm/sec	14 cm/sec	16 cm/sec	20 cm/sec

**Standard speed from factory*

3. To confirm your choice of speed, press on the "PROG" button.
4. You can now choose a new selection by pressing on the "UP" button on the hand control, if not turn the lift off then turn it back on by gently pulling on the red cord; this will return the lift to normal use.

C) Adjust the height of the spreader bar when it returns to charger

1. Enter into "Service" mode and select #2. (Consult section A of **Programming the Lift**).
2. The strap will completely rewind.
3. Once the spreader bar is completely rewound, use the "UP" and "DOWN" buttons to position the spreader bar to the desired height when returning unit to charger.
4. To confirm the height desired, press on the "PROG" button.
5. You can now choose a new selection by pressing on the "UP" button on the hand control, if not turn off the lift and turn it back on by gently pulling on the red cord; this will return the lift to normal use.

D) Enable / Disable – Return to charge

Return to charge function is enabled at factory. The return to charger function can be disabled by user.

1. Enter into "SERVICE MODE" and select the 3rd choice (section A).
2. Use hand control left button to select ENABLE, ENABLE LEFT or RIGHT or DISABLE selection.

1 beep*	2 beeps	3 beeps	4 beeps
ENABLE AUTOMATIC	DISABLE	ENABLE LEFT	ENABLE RIGHT

**Standard from factory*

3. To confirm your selection press on the "PROG" button.
4. Now you can choose a new selection by pressing on the "UP" button on the hand control, if not, turn off the lift and it back on by gently pulling on the red cord to return the lift to normal use.

MAINTENANCE



ALWAYS CARRY OUT THE DAILY CHECKLIST BEFORE EACH LIFT USE.

Alterations made to the MAXI SKY 1000 by someone other than a certified technician may cause serious injury and voids the warranty.

The MAXI SKY 1000 and accessories must be inspected **ANNUALLY** by a certified technician in addition to the daily and other periodic visual checks done by the user specified in this section.

Preventive maintenance specified in this manual can prevent accidents and reduce repair costs.

Note all service or repairs to the MAXI SKY 1000 or its accessories in the logbook at the end of this manual. Have the document signed by the certified technician

Daily Check List

THE FOLLOWING PROCEDURES MUST BE FOLLOWED BEFORE EACH USE:

- Have batteries been charged? Park the lift on the charger whenever the lift is not in use.
- Inspect the lift for any damage. If the lift casing does not look properly aligned, or there are any cracks or other damage on the lift, or any parts are missing – **DO NOT USE IT**. Contact your local representative to have the lift serviced.
- Inspect the visible strap for any signs of wear, frays, loose threads or other damage. If there is any evidence of damage – **DO NOT USE IT**. Contact your local representative to have the lift serviced.
- Inspect the sling for tears, frayed straps or loose stitches. If the sling has any of the above damage – **DO NOT USE IT**. Contact your local representative to have the sling replaced or repaired.
- Inspect the spreader bar for any signs of the cracking or damage.
- Ensure the split ring and cotter pins that attach the spreader bar to the strap are secure.

Inspection and Cleaning

Clean the MAXI SKY 1000 with a soft dry cloth, or a soft cloth lightly moistened with a mild detergent solution. Do not use any type of solvent that may damage the finish.



Do not immerse lift in water.

To ensure a better rolling surface for the trolley wheels, clean the inside of the track every 4 months. To do so, insert a damp cloth in the opening and slide it from one end of the track to the other.



Always reinstall the rail end stopper (if it has been removed) after servicing.

Strap Inspection

This equipment is built with a strap that can withstand a load of 2275 kg (5000 lbs.) Nonetheless, if this strap is damaged or shows signs of wear, the acceptable load on the strap before rupture can drop rapidly and present a danger for the patient or caregiver.

Arjo recommends thoroughly inspecting the strap every 2 months as follows:

1. Completely unwind the strap.
2. Look for any signs of wear:



Loose threads in stitched area.

Noticeable discoloration by having a lighter color strap than the double thickness stitched area.

Side wear.

Middle wear.



If there is any sign of wear as indicated here or other visual defects, strap should be changed immediately. By continuing to use the lift without changing the strap, caregiver and patient safety is greatly compromised.

In any case, the manufacturer recommends changing the strap at least every two years. By continuing to use the lift without changing the strap, caregiver and patient safety is greatly compromised.

Take note of inspection results in the logbook at the end of this manual.

Handling and Storage

Avoid violent shock during transportation.

The lift should not remain stored more than two months without recharging the batteries.

If you store or ship the MAXI SKY 1000 lift, turn the power off (green light off).

Battery Replacement

ARJO uses sealed lead-acid batteries. Contrary to nickel-cadmium, ARJO batteries do not have any memory effect. Therefore, batteries should not be completely discharged before recharge.

Replace the battery when there is a noticeable reduction in the number of transfers that can be performed between charges. If you notice the MAXI SKY 1000 lift "beeping" and a red light flashing, see the instructions in "Troubleshooting" to ensure it is a problem with the battery.

To replace a battery, contact your local dealer or representative.



DO NOT ATTEMPT TO USE A BATTERY NOT AUTHORIZED BY ARJO.

ARJO batteries are specially designed for ARJO charging systems. Attempting to use an unauthorized battery may seriously damage the lift and/or the charger.

Verification of Charger Power Source

If the light does not illuminate when there are batteries in, do the following steps:

1. Make sure that the power cord is correctly plugged into the charger in the wall and clip on charging station indicator green light is on.
2. Make sure that there is contact between the contact plates of the lift and the circuit board of the charging station.
3. Check the power of the outlet.
4. If the yellow or green light of the charging station do not light up, contact your local dealer or representative for assistance.

Sling Inspection and Care

For maximum patient safety and hygiene, read the following instructions:

Chemical Attack

Oil, grease, creosote or paint stains are harmless but other forms of chemical attack of a

sufficient degree may lead to deterioration or extreme softening of the webbing, which could lead to the fibres being rubbed off (almost as powder in extreme cases). It is best to avoid fumes, spray or mists of acid and alkalis or organic solvents. If contamination is suspected, wash out well in warm water. Avoid contact with excessive heat, which is likely to affect the product.

Cleaning

Certain chemical substances mentioned above may be removed with heavy duty cleaner diluted in warm water. Ensure that any cleaning agents are removed by rinsing thoroughly in warm water, maximum 60°C (140°F).

For normal washing and cleaning, follow the care instructions on the label of the product.

Storage

Slings should be stored away from direct sunlight, stress, pressure, excessive heat or humidity. The sling should be kept away from contact with sharp objects, corrosives or other possible damaging material.

1. Check for any sign of wear on sling straps as described above and at the strap-sling junction. Buckles on certain slings should be checked to ensure that the locking/unlocking mechanism opens and closes easily and is secure when locked.

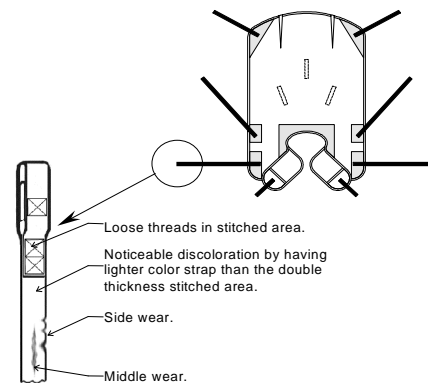

2. Check for any sign of deterioration of the sling material. Check for general external wear, local abrasion, cuts, holes or burns in the webbing and for chemical attack.
3. Look at "stitched areas" for broken, worn, pulled or unraveled stitches.
4. Sling should be cleaned as indicated on the tag.

If there is any sign of wear or deterioration as indicated above or other visual defect, sling should be changed immediately. By continuing to use the lift without changing the sling, care giver and patient safety is greatly compromised



Take note of inspection results in the logbook at the end of this manual.

Annual Inspection

The MAXI SKY 1000 and its accessories must be inspected annually by a certified technician.



MAXI SKY 1000 AND ACCESSORIES MUST BE SERVICED EVERY 12 MONTHS AS A MINIMUM REQUIREMENT.

Do not attempt to do the inspection unless you are certified to do so.

As part of the annual inspection, an annual load test with the safe working load must be performed on the MAXI SKY 1000.

After annual inspection, have the logbook signed by the certified technician.

Maintenance Requirements

The MAXI SKY 1000 is equipped with an electronic monitor. This red light will flash when a maintenance inspection is necessary to ensure the durability of the unit and the security of the patient and user.

Once this light red begins to flash please contact your local dealer/representative in order to perform the necessary maintenance inspection requirements.

ERGOFIT SLINGS

Every patient has different needs. It is very important to choose the right sling based on the needs of the patient to be transferred as well as their physical ability and size.

All Ergofit slings are made from a Polyester/ Nylon material, which is soft and pliable, easy to care for, and install. All slings are machine wash and dry on medium temperature. Ergofit slings are covered by a one-year warranty.





- **PLEASE READ THE FOLLOWING CAREFULLY, BEFORE USING A ARJO ERGOFIT SLING.**
- **ALWAYS CARRY OUT THE DAILY CHECKLIST BEFORE EACH LIFT USE.**
- **ARJO CEILING LIFTS ARE SPECIFICALLY DESIGNED FOR ARJO SLINGS AND ACCESSORIES. SLINGS AND ACCESSORIES DESIGNED BY ANY OTHER MANUFACTURER ARE PROHIBITED AND WILL VOID ARJO'S WARRANTY. USE ONLY ARJO SLINGS AND ACCESSORIES TO MAINTAIN PATIENT SAFETY AND PRODUCT UTILITY.**
- **PATIENT TO BE TRANSFERRED MUST BE ASSESSED BY A QUALIFIED PROFESSIONAL BEFORE ATTEMPTING TO TRANSFER.**
- **OBSERVE A TRAINED EXPERT TO PERFORM THE TRANSFER PROCEDURES AND THEN PRACTICE THEM SEVERAL TIMES WITH A CAPABLE INDIVIDUAL ACTING AS PATIENT BEFORE ATTEMPTING A TRANSFER WITH A PATIENT WITH LIMITED CAPABILITIES.**
- **READ CAREFULLY ALL INSTRUCTIONS BELOW BEFORE ATTEMPTING TO INSTALL A SLING.**
- **IF YOU HAVE ANY DOUBTS, PLEASE CONTACT YOUR LOCAL REPRESENTATIVE.**
- **USE A SLING RECOMMENDED BY THE PATIENT'S PHYSICIAN, NURSE OR MEDICAL SPECIALIST AS AP-PROPRIATE FOR THE PATIENT'S ABILITY AND NEEDS.**
- **DO NOT USE ANY KIND OF PLASTIC BACKED INCONTINENCE PAD OR SEATING CUSHION BETWEEN THE PATIENT AND SLING MATERIAL. THIS MAY CAUSE THE PATIENT TO SLIDE OUT OF THE SLING DURING A TRANSFER.**
- **DO NOT EXCEED THE MAXIMUM WEIGHT LIMITATION OF THE SLING.**
- **WHENEVER POSSIBLE, HAVE SOMEONE ASSIST YOU TO ENSURE THE PATIENT'S SAFETY AT ALL TIMES.**

Laundry Instructions for all slings:

The following symbols are used on sling labels and related to washing instructions:

 Maximum washing temperature is 60°C (140°F) for permanent cycle.

 Do not use bleach.

 Do not dry clean.

 Tumble dry low temperature.

 Do not iron.

Bariatric Sling (TOB)

Our truly bariatric size sling is designed for the special needs of a bariatric patient weighing from 182 to 455 kg (400 to 1000 lbs.). Polyester/nylon material moves easily to reduce friction on tender skin. The area around the legs and buttocks is padded, adding additional support and comfort. Positioning loops and handles allow you to adjust the position the person is transferred in as well as position the person properly into a chair. The bariatric sling is designed to be used only in conjunction with the 4-point frame support. The frame and the sling fit to MAXI SKY 1000 overhead ceiling lift and the Ergolift-600 mobile lift. The weight capacity is 455 kg (1000 lbs). It is available in one size only.

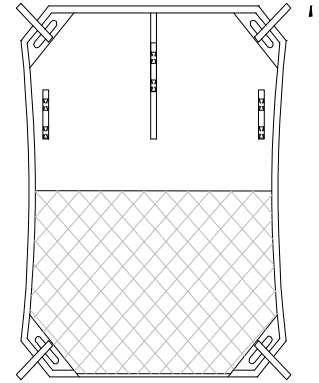

Sling Placement- from laying position

1. The sling has two sides, the white fabric indicates the side that is intended to be next to the patient and the label and handles are on the outside. The upper part of the sling is in a white material and the lower part is padded.
2. Fold the sling in half lengthwise with the white part of the sling on the inside of the fold and place next to the patient to be transferred.



When transferring a patient from a bed, have people on each side of it, or raise the bed rails to ensure the patient does not roll off the bed.

3. With someone there to assist you, carefully roll the patient onto one side. Now place the fold of the sling at the center of the bed or where the spine of the patient will be. Lift the top fold and tuck next to the patient.
4. Lower the patient down on top of the sling. Roll the patient the opposite direction to pull the sling out the other side.

Sling attachment to Spreader bar

1. Ensure the sling is properly placed underneath the patient according to the instructions above.
2. Adjusting the sling loops higher or lower. The choice of the colour of the loops must be the same at each four attachment points.
3. Make sure the patient's arms are over top of the sling and that it is not caught on any obstructions (wheelchair brake or handle).
4. See "Operation" section for next step..



MAINTENANCE INSPECTION CHECKLIST

MAINTENANCE INSPECTION CHECKLIST

TO BE INSPECTED BY USER						
ITEM	INITIALLY	BEFORE EVERY USE	EVERY 2 MONTHS	EVERY 4 MONTHS	EVERY YEAR	EVERY 2 YEARS
LIFT DEVICE						
Inspect for missing hardware or broken panel.	X	X			X	
Inspect strap for wear.		X	X			
Recharging batteries.		X				
Make that rail end stoppers are in place		X				
Inspect the spreader bar on the strap of the lift for damage or cracks.					X	
Inspect wheels in rail for damage, rust or cracks. Replace if damaged.					X	
Clean the rail and the Clip on charging station contacts.				X		
Overall inspection by authorized personnel.					X	
SLING AND HARDWARE						
Check all sling attachments for sign of wear.		X				
Inspect sling material for wear or deterioration.		X				
Inspect sling straps for wear.		X				
Inspect for any defects or loose threads in the "stitched areas".		X				
Cleaning sling as indicated on the tag.	<i>When necessary</i>					
Verify emergency stop cord				X		
Verify emergency lowering device.				X		

MAINTENANCE BY A CERTIFIED TECHNICIAN						
Replace strap						X
Inspect the welding aspect on the frame to detect cracks					X	
Inspect sprockets for wear.					X	
Inspect connecting joints for proper attachment					X	
Verify the emergency brake on the drum is turning freely.					X	
Verify emergency devices for good functioning.					X	
Load test with the SWL (maximum working capacity)					X	
Rail end stoppers inspection					X	

	<p>Maintenance inspection points are suggested by the manufacturer, however in certain cases, some inspections should be done on a more frequent basis. By continuing to use the lift without replacing the listed parts in this maintenance inspection checklist, caregiver and patient safety is greatly compromised.</p>
---	---

TROUBLESHOOTING



DO NOT attempt to open the MAXI SKY 1000 lift. Only a certified technician is authorized to open the MAXI SKY 1000 lift.

Alterations made to the MAXI SKY 1000 by someone other than a certified technician may cause serious injury.

PROBLEMS	TO CHECK
The red light « Service » is on and flashing.	<ul style="list-style-type: none"> Contact your supplier or your local representative to do the maintenance.
The red light is solid.	<ul style="list-style-type: none"> The lift is under overheat protection. Wait between 10 and 30 minutes until the red light turns off and press on the UP button to lift again.
The unit starts and stops repetitively.	<ul style="list-style-type: none"> If the load is over the safe working load, the unit will not work due to an overload protection on the motor.
The lift emits a "beep" during utilisation. The unit may stop lifting but can still lower it.	<ul style="list-style-type: none"> Batteries are low. Return the lift to the clip on charging station.
Charge indicator on the lift (yellow) does not light up when the lift is on the charger.	<ul style="list-style-type: none"> Is the clip on charging station is plugged into a standard outlet? If so, does the outlet have power? Clip on charging station indicator green light confirms the functionality of the charger.
When returning to charge, the lift passes the Clip on charging station or takes the wrong direction.	<ul style="list-style-type: none"> Clean the contact blades of the charging station with mild detergent. Turn on the lift and pass the lift through the charging station once manually, then retry the automatic return to charger.
Batteries are always dead after a few transfers (3 to 5).	<ul style="list-style-type: none"> Verify the functioning of the lift charger and the contact fingers on the clip on charging station. Replace batteries by new ones. The life of the current one is probably over. It is important to always change both batteries at the same time. (Contact your local dealer or your representative to have batteries replaced)
The light on the charger shows a solid yellow yet the lift will only do one or two transfers.	<ul style="list-style-type: none"> Contact your local dealer or representative to have batteries replaced.
The light on the charger shows yellow yet the lift will only work when there is no one on the lift. When you attempt to transfer someone, the lift stops.	<ul style="list-style-type: none"> Contact your local dealer or representative to have batteries replaced.
The lift does not work when you press the buttons on the hand control.	<ul style="list-style-type: none"> Is the charger light is on? The lift must be moved away from the charger in order to operate. . Is the emergency stop activated? Gently pull the red cord once until the green light is on. Are the buttons on the lift functioning? If so, the problem may come from the hand control connection. If not, check the charge on the lift. Is the hand control properly plugged into the lift? The hand control may be slightly pulled out its socket yet appear as though it is plugged in. Pull out the plastic cover to check the connection. Slide the lift over the clip on charging station. Is the yellow light on? If, after testing all of the above, the lift will not operate, contact your local dealer or your representative.
The charging light on the lift remains flashing yellow and does not turn yellow	<ul style="list-style-type: none"> If available, try another integrated clip on charging station from another lift or a spare one; plug it into the rail and

TROUBLESHOOTING

PROBLEMS	TO CHECK
after and overnight charge.	<p>charge for 3 hours. If the yellow light is still flashing, contact your local dealer or your representative.</p> <ul style="list-style-type: none">• Use a voltmeter, test two contact points on the charger (See diagram T-1). The voltmeter should read between 26-30 volts VDC.• Contact your local dealer or your representative.

DIAGRAMME T-1

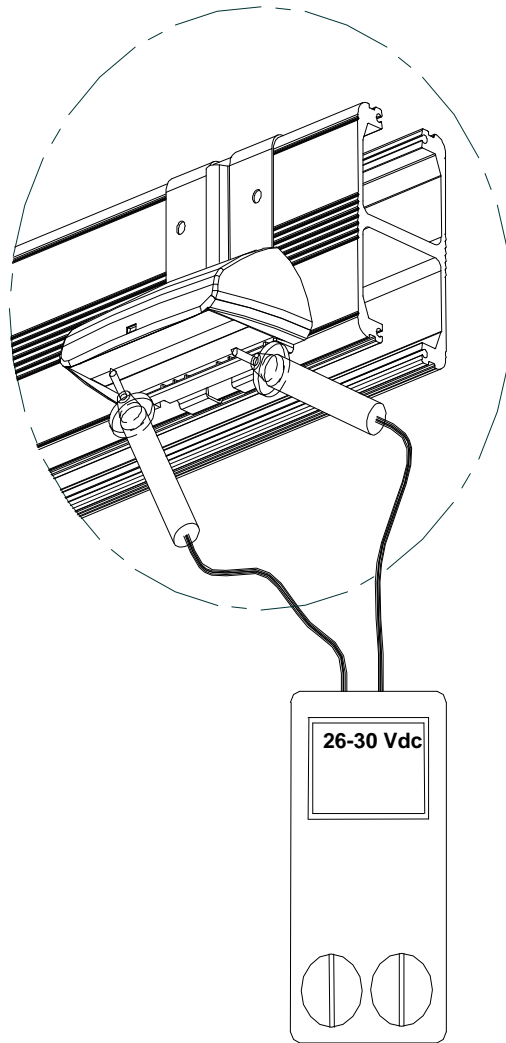

ACCESSORIES

CHARGER AND CLIP ON CHARGING STATION

Product #700.15500



2-METER CHARGER EXTENSION

Product #402.15505

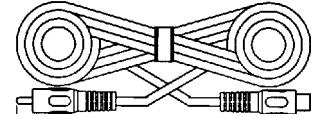

FIDO CONTACT STATION

Product number: 700.15400.33

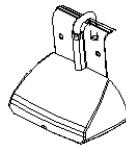

CHARGER POWER CORD UK

Product No.

- 402.00001 – USA (UL)
- 402.00002 – Japan
- 402.00003 – CE (Europe)
- 402.00004 – Australia
- 402.00005 - UK

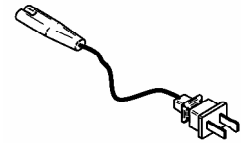

RAIL STOPPER

Product #700.11005

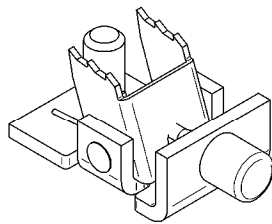

4-HOOK SPREADER BAR FOR MAXI SKY 1000

Product #700.05570.33 (only use with the TOB Sling)

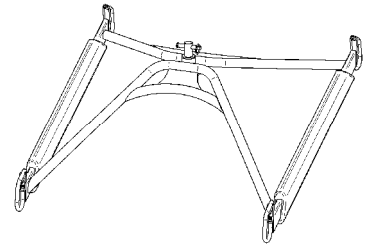

HAND CONTROL FOR MAXI SKY 1000

6-buttons - Product #700.13650.33

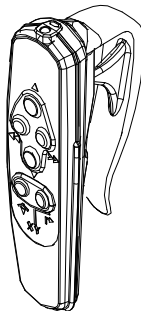

TOB SLING

*Only use with the 4 hooks spreader bar 700.05550

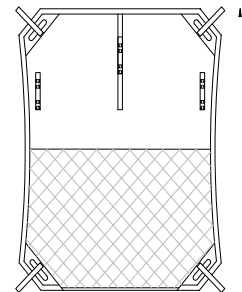

LOGBOOK

Product Name : MAXI SKY 1000 – (LFXXXXX series)

Product Serial Number :

Date of purchase :

Warranty Period :

Distributed By :

Owner Checklist :

- Ensure the lift is serviced regularly as per the Maintenance Inspection Checklist on page 48.
- Contact an authorized Arjo Distributor / Service Agent immediately if there are any problems with the operation of the device.
- Ensure the logbook is completed and signed.
- Record any repairs required.
- Withdraw the patient lifter from service if inspection reveals that user safety is jeopardized in any way from use of the patient lifter.

TO BE COMPLETED AFTER EACH SERVICE OR INSPECTION

Service Type	Pre-delivery	Periodic inspection	Minor	Major
Condition report :				

Action taken :				

Date :		Inspected by:		
_____		_____		
		Printed	Signature	

Service Type	Pre-delivery	Periodic inspection	Minor	Major
Condition report :				

Action taken :				

Date :		Inspected by:		
_____		_____		
		Printed	Signature	

Service Type	Pre-delivery	Periodic inspection	Minor	Major
Condition report :				

Action taken :				

Date :		Inspected by:		
_____		_____		
		Printed	Signature	

Service Type	Pre-delivery	Periodic inspection	Minor	Major
Condition report :				

Action taken :				

Date :		Inspected by:		
_____		_____		
		Printed	Signature	

Service Type	Pre-delivery	Periodic inspection	Minor	Major
Condition report :				

Action taken :				

Date :		Inspected by:		
_____		_____		
		Printed	Signature	

Service Type	Pre-delivery	Periodic inspection	Minor	Major
Condition report :				

Action taken :				

Date :		Inspected by:		
_____		_____		
		Printed	Signature	

WARRANTY

This warranty is extended only to the original purchaser/user of ARJO products.

Arjo Inc. warrants its products to be free from defects in material under normal use and service, within the periods stated below from the date of purchase. If within such warranty period any such product shall be proven to be defective, such product shall be repaired or replaced at Arjo option. This warranty does not include any labor or shipping charges incurred in replacement part installation or repair of any such product. Arjo sole obligation and your exclusive remedy under this warranty shall be limited to such repair and/or replacement.

Patient Lifter	1 year
Tracks and installation	Life time warranty*
Weighing Devices	1 year
Accessories on Lifter	1 year
Slings	1 year
Batteries - Voyager Portable	3 months
Batteries - All other lifts	1 year
Easytrack System	1 year

For warranty service, please contact the dealer from whom you purchased the Arjo product.

Do not return products to our factory without prior authorization. Arjo will issue a Return Merchandise Authorization (RMA) Number. C.O.D. shipments will be refused; all shipments to Arjo must be prepaid. For this warranty to be valid, the purchaser must present its original proof of purchase at the moment of the claim. The defective unit, assembly or part must be returned to Arjo for inspection. The part or components repaired or replaced are guaranteed for the remaining period of the initial warranty.

Limitations and Exclusions:

The warranty above does not apply to serial numbered products if the serial number has been removed or defaced.

No warranty claim shall apply where the product or any other part thereof has been altered, varied, modified, or damaged; either accidentally or through improper or negligent use and storage. Warranty does not apply to products modified without Arjo express written consent (including but not limited to products modified with unauthorized parts or attachments), products damaged by reason of repairs made to any component without the specific consent of Arjo, or to products damaged by circumstances beyond Arjo control. Arjo will solely determine evaluation of warranty claim. The warranty does not apply to problems arising from normal wear or failure to adhere to the instructions in this manual. Arjo Inc. slings are void of warranty if not laundered as per instructions on the Sling Label.

Arjo Inc. shall not be liable for damages losses or inconveniences caused by a carrier.

This warranty replaces any other warranty expressed or implicit and constitutes Arjo Inc. only obligation towards the purchaser. Arjo shall not be liable for any consequential or incidental damages whatsoever.

* Valid only if Arjo did the original installation. Warranty voids if tracks/installation have been modified.

